

FOR SAFETY MEASUREMENTS

Prior to use, to avoid an electrical shock hazard to the operator and/or damage to the instruments, read carefully the WARNINGS with the symbol \triangle listed in 「4. SAFETY PRECAUTIONS」, 「5. MEASUREMENT PROCEDURES」 and 「6. MAINTENANCE」 of this instruction manual.

Important Symbol

\triangle : The symbol listed in IEC 61010-1 and ISO 3864 means "Caution (refer to instruction manual)".

\triangle **WARNING** : The symbol in this manual advises the user of an electrical shock hazard that could result in serious injury or even death.

\triangle **CAUTION** : The symbol in this manual advises the user of an electrical shock hazard that could cause injury or material damages.

\triangle WARNING

High Power Line is very dangerous and/or lethal to measure. High Power Line sometimes includes High Surge Voltage that could possibly induce dangerous arcs of explosive short in the instrument and could result in serious injury to the operator. When measuring dangerous voltages of High Power Line or High Voltage Circuit, always place the instrument away from your body without holding it with your hands. Do not touch the Clamp Meter, its Test Leads, or any part of the circuit while it is on.

CONTENTS

1. INTRODUCTION	2
1-1. GENERAL	2
1-2. FEATURES	2
1-3. UNPACKING AND INSPECTION	2
2. SPECIFICATIONS	3
2-1. GENERAL SPECIFICATIONS	3
2-2. MEASUREMENT SPECIFICATIONS	4
3. NAME ILLUSTRATION	7
4. SAFETY PRECAUTIONS	12
4-1. WARNINGS	12
4-2. GENERAL WARNINGS AND CAUTIONS	17
5. MEASUREMENT PROCEDURES	17
5-1. PREPARATION FOR USE	17
5-2. CURRENT ($\overline{\bar{A}}$, \tilde{A} , Hz) MEASUREMENTS	20
5-3. VOLTAGE ($\overline{\bar{V}}$, \tilde{V} , Hz , %) MEASUREMENTS	21
5-4. RESISTANCE (Ω) MEASUREMENTS	23
5-5. CONTINUITY (\bullet) TESTS	24
5-6. DIODE (\blacktriangleleft) TESTS	25
5-7. CAPACITANCE (\blacktriangleleft) MEASUREMENTS	27
6. MAINTENANCE	28
6-1. WARRANTY STATEMENT	28
6-2. BATTERY REPLACEMENT	28
6-3. PERIODICAL CHECK AND CALIBRATION	30
6-4. REPAIR	30

— 1 —

1. INTRODUCTION

1-1. GENERAL

SK-7718/7719 are micro-computer controlled, most compact and all-purpose AC/DC Digital Clamp Meters.

They are provided with easy to read 4000 count LCDs and can measure 1000A AC/DC with Advanced Testing Functions such as Peak Hold (SK-7718 only), Max/Min, etc, that are very useful for testing and maintaining multifarious electric appliances / apparatus and equipments / facilities. They are also designed with usability in mind for checking electric systems of motorcars.

The reliable and tough instruments, SK-7718/7719 ensure accurate measurements with every targets.

1-2. FEATURES

1. AC/DC 1000A MEASUREMENTS

Provided with AC/DC 1000A, AC/DC 600V, 40M Ω , \bullet , \blacktriangleleft and \blacktriangleleft measurements, SK-7718/7719 present versatility.

2. ADVANCED TESTING FUNCTIONS

Peak Hold (SK-7718 only), Max/Min and Difference measurements are available as well as Display Hold.

3. Easy Use and Reading

Handy compact body and 4000 count LCD with units and symbols.

4. DUST - PROOF AND WATER - RESISTANT CASES

Both models are designed of Dust-proof and Water-resistant to protect PCB and switches. But not with Clamp Head.

5. SAFETY DESIGN

Designed with user's safety in mind, CE Mark is approved complied with EMC and LVD (IEC 61010-1).

6. AUTO POWER OFF

Power is automatically turned off after about 12 minutes of power on. Battery Consumption is prevented when power-off is forgot.

1-3. UNPACKING AND INSPECTION

Before unpacking, examine the shipping carton for any sign of damage. Unpack and inspect the instrument and accessories for

any damage from mechanical shock, water leakage, or other causes. If any damage or missing item is found, consult the local dealer for replacement.

Make certain that following items are included in the box.

1. Digital Clamp Meter
2. One pair of Test Leads (100-57 complies with IEC spec.)
3. One 9V 6F22 Battery
4. Instruction Manual
5. 1012 Carrying Case

2. SPECIFICATIONS

2-1. GENERAL SPECIFICATIONS

1. DISPLAY:

- a. **Numerical Display** ; 4000 Count LCD, Max 9999, 12mm high.
- b. **Units and Symbols** ; A, mV, V, Hz, kHz, %, Ω , k Ω , M Ω , \bullet , \blacktriangleleft , nF, μ F, ∞ , \sim , —, BAT, AUTO, PH (SK-7718), DIFF, DH, MAX, MIN, OL and decimal point.

2. OPERATING PRINCIPLE : Σ Δ Conversion.

3. MEASURING PRINCIPLE : SK-7718 : True RMS (AC Coupling) SK-7719 : Average Rectification

4. SAMPLING RATE : 3 times/sec.

5. RANGE SELECTION : SK-7718 : Autoranging SK-7719 : Autoranging and Manual-ranging

6. POLARITY: Autopolarity, — symbol when minus, + symbol is implied.

7. OVERLOAD INDICATION : OL symbol is shown. (excluding AC/DC 600V, 1000A range)

8. BATTERY WARNING : BAT symbol is shown.

9. DISPLAY HOLD : Display is held by DH Key.

10. MAX/MIN : Maximum and Minimum Values are measured by MAX/MIN Key on $\overline{\bar{A}}$, \tilde{A} , $\overline{\bar{V}}$, \tilde{V} and Ω .

11. PEAK HOLD : Up to ∞ / \sim 1500A, 1000V peak. (SK-7718 only) Peak Value is measured at 10m Sec. in PH Mode.

12. DIFF (Difference) : Desired value being measured is stored and converted to read zero on LCD and only difference is shown with proceeding measurements.

Also use this Key to take zero on DC Current or Peak Hold measurements only when necessary.

— 2 —

— 3 —

13. **CONTINUITY TEST** : Buzzer sounds in case less than approx. 50Ω
14. **OVERLOAD PROTECTION** :
- Current ; ~ / ≡ 1500A rms (600V Line) for one minute.
 - Voltage ; ~ / ≡ 900V rms for one minute.
 - Resistance ; ~ / ≡ 300V rms for one minute.
15. **DIELECTRIC STRENGTH** : 5.55 kV (Sine Wave) for one minute between Case and Input Terminals
16. **OPERATING TEMPERATURE & HUMIDITY** : 0°C to 40°C, less than 80% in non-condensing.
17. **STORAGE TEMPERATURE & HUMIDITY** : -20°C to 60°C, less than 70% in non-condensing.
18. **TEMPERATURE COEFFICIENT**: When 0°C to 18°C and 28°C to 40°C, (Accuracy on condition of 23°C±5°C) × 0.1/°C
19. **SAFETY LEVEL** : CE Mark authorized. IEC 61010-1 Overvoltage Category III 600V and EMC Test passed.
20. **POWER SUPPLY** : 9V 6F22 (S-006P) × 1
21. **POWER CONSUMPTION** : SK-7718 : Less than 90mW, approx. 25 hours. / SK-7719 : Less than 75mW, approx. 29 hours continuous operation.
22. **AUTO POWER OFF** : LCD is automatically turned off under power off condition after 12 minutes of power on.
23. **CONDUCTOR DIAMETER** : 35mm φ.
24. **DIMENSIONS & WEIGHT** : 193(H) × 60(W) × 34.5(D)mm, 300g.
25. **OPTIONAL ACCESSORIES** : 880 Line Separator, 940 Alligator Clips

2-2. MEASUREMENT SPECIFICATIONS

(23°C±5°C, less than 80% RH)

1. Current Measurements (\bar{A} / \tilde{A} → Hz →)

1-1. DC Current (≡ A)

Range	Resolution	Accuracy	Max. Input Current
400.0A	0.1A	±1.5%rdg±3dgt	400A DC
1000 A	1 A	400~600A : ±1.5%rdg±3dgt 601~1000A : ±3.0%rdg±3dgt	1000A DC

* Range Selection (Manual-ranging) : SK-7719 only

1-2. AC Current (~ A)

SK-7718 : True RMS (AC Coupling)
SK-7719 : Average Rectification

Range	Resolution	Accuracy (50/60Hz)	Max. Input Current
400.0A	0.1A	±1.5%rdg±5dgt	400A rms
1000 A	1 A	400~600A : ±1.5%rdg±5dgt 601~1000A : ±3.0%rdg±5dgt	1000A rms

- 4 -

2-3. Frequency (Hz)

Range	Accuracy	Resolution	Input Sensitivity
1.000Hz~4.999Hz	±0.2%rdg±2dgt	1 mHz	5V rms
5.00Hz~49.99Hz		10 mHz	
50.0Hz~499.9Hz		100mHz	
0.500kHz~4.999kHz		1 Hz	
5.00kHz~49.99kHz		10 Hz	

* Max.Input 300V rms * Autoranging only

2-4. Duty Cycle (%)

Range	Accuracy	Resolution	Input Sensitivity	Max. Input
10%~90%	±2.0%rdg±2dgt	0.1%	3V (Square wave)	300V rms

* Frequency Range : 1Hz~1kHz

2-5. Peak Hold (≈ 1000V)

(SK-7718 only)

Range	Resolution	Accuracy (Pulse width:10ms)	Max. Input
600 V	1 V	±5.0%rdg±5dgt	1000V

3. Resistance (Ω)

Range	Accuracy	Resolution	Measurement Current	Open Circuit Voltage
400.0 Ω	±1.5%rdg±5dgt	0.1 Ω	≤0.3mA	≈0.4V
4.000 kΩ	±1.0%rdg±3dgt	1 Ω	≤40 μA	
40.00 kΩ		10 Ω	≤4 μA	
400.0 kΩ		100 Ω	≤0.4 μA	
4.000 MΩ	±4.0%rdg±5dgt	1kΩ	≤40 nA	
40.00 MΩ	±6.0%rdg±5dgt	10kΩ		

* Overload Protection : 300V rms 1minute.

* Range Selection (Manual-ranging) : SK-7719 only

4. Continuity (•||))

Range	Buzzer	Resolution	Measurement Current	Open Circuit Voltage
400.0Ω	< ≈ 50 Ω	0.1 Ω	≤0.4mA	≈0.44V

* Overload Protection : 300V rms 1minute.

- 6 -

- * Range Selection (Manual-ranging) : SK-7719 only
- * Crestfactor : 400A less than 3, 1000A less than 1.5. (SK-7718 only)
- * Accuracy : 40~400Hz ; add 1.5%rdg.

1-3. Frequency (Hz)

Range	Accuracy	Resolution	Input Sensitivity
1.000Hz~4.999Hz	±0.2%rdg±2dgt	1m Hz	5A rms
5.00Hz~49.99Hz		10m Hz	
50.0Hz~499.9Hz		100m Hz	
0.500kHz~1.000kHz		1 Hz	

* Max.Input 1000A rms * Autoranging only

1-4. Peak Hold (≈ 1500A)

(SK-7718 only)

Range	Resolution	Accuracy (Pulse width:10ms)	Max. Input
1000 A	1 A	±5.0%rdg±5dgt	1500A

* Less than 50A is not specified. * 2~3 digits remain.

2. Voltage Measurements (\bar{V} / \tilde{V} → Hz → % →)

2-1. DC Voltage (≡ V)

Range	Accuracy	Resolution	Input Resistance	Max. Input Voltage
400.0mV	±1.0%rdg±3dgt	0.1mV	≥100MΩ	600V DC
4.000 V		1mV	≈11MΩ	
40.00 V		10mV	≈10MΩ	
400.0 V		100mV		
600 V		1V		

* Range Selection (Manual-ranging) : SK-7719 only

2-2. AC Voltage (~ V)

SK-7718 : True RMS (AC Coupling)
SK-7719 : Average Rectification

Range	Accuracy	Resolution	Input Resistance	Max. Input Voltage
4.000 V	±1.0%rdg±5dgt (40~400Hz)	1 mV	≈11MΩ	600V rms
40.00 V		10 mV	≈10MΩ	
400.0 V		100 mV		
600 V		1 V		

* Crestfactor : 400V less than 3, 600V less than 2. (SK-7718 only)

* Range Selection (Manual-ranging) : SK-7719 only

- 5 -

5. Diode Tests (⇄)

Range	Accuracy	Resolution	Open Circuit Voltage	Overload Protection
0~1.5V	±5.0%rdg±5dgt	1mV	≤1.7V	300V rms 1minute

6. Capacitance (⇄)

Range	Accuracy	Resolution	Open Circuit Voltage	Overload Protection
50.00 nF	±5.0%rdg ±10dgt	10pF	≤1.7V	300V rms 1minute
500.0 nF		100pF		
5.000 μF		1nF		
50.00 μF		10nF		
100.0 μF		100nF		

* Autoranging only

3. NAME ILLUSTRATION

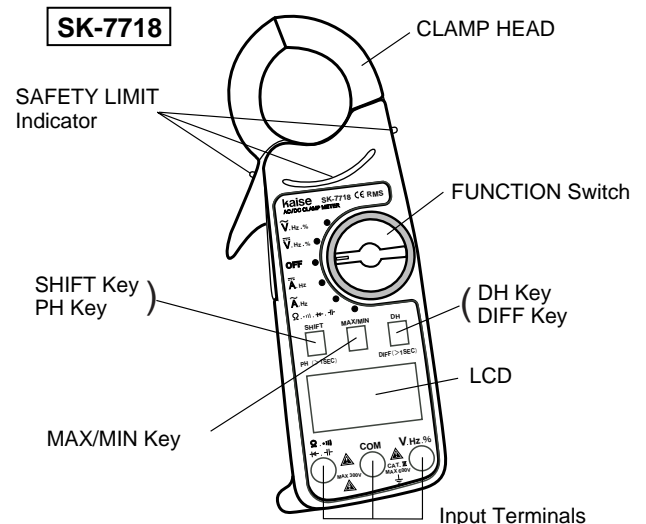

- 7 -

SK-7719

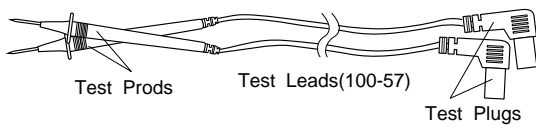
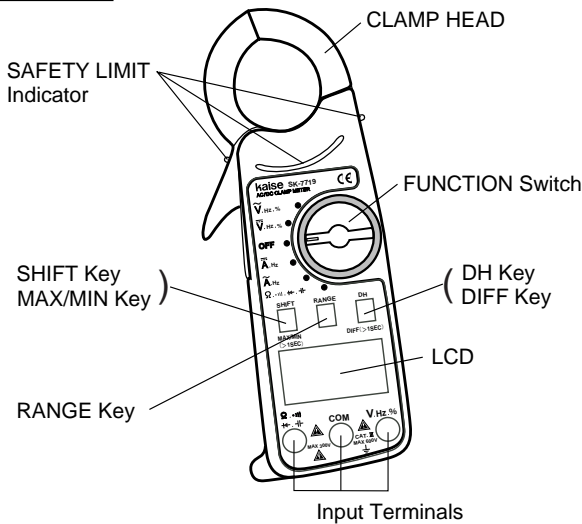

Fig. 1

1. FUNCTION Switch

Set FUNCTION Switch to a desired position, A, V or Ω and set it to OFF position when measurements are finished.

2. SHIFT Key : $\text{Hz} \rightarrow \%$, $\Omega \rightarrow \text{diode}$, $\text{diode} \rightarrow \text{diode}$

Press this Key to select Hz in Current Measurement, Hz and % in Voltage Measurement, and to select Ω , diode, and Capacitance Measurement.

NOTE: When continuous measurements more than 10 minutes are necessary, set Function Switch to A, V or Ω position with SHIFT Key pressed on for less than one second. APO symbol is not displayed on LCD and Auto Power Off does not work during measurements.

3. PH Key : Peak Value Measurements up to $\text{AC} \sim 1500\text{A}$, 1000V (SK-7718 only)

- 3-1. Clamp Head is placed away from conductor and Input is zero.
- 3-2. Under this condition, press PH Key for more than 1 second. About 2~3A and PH symbol are shown on LCD.
- 3-3. Open Clamp Head and clamp on a single conductor and read Peak Value on LCD.
- 3-4. Remove Clamp Head from the conductor and press PH Key for more than 1 second. PH symbol disappears and PH Key is canceled.

4. DH Key : Display Hold

Press this Key for less than 0.5 second. DH symbol is shown and display is held. To cancel this Key, press it again.

5. DIFF Key : Difference Measurements

DIFF Key is used to make Difference Measurements. When measuring a value or applying a desired value into the instrument, press DIFF Key for more than 1 sec and the input value is stored and converted to read 0±1 digit on LCD with DIFF symbol displayed. The difference between the stored value and a measuring value is displayed on LCD with preceding measurements.

To cancel DIFF Key, press DIFF Key for more than 1 second.

NOTE: When DIFF Key is on, DH Key or MAX/MIN Key can work.

NOTE: The Maximum input Values are the same even when DIFF Key is on, do not make measurements that will exceed the maximum input values.

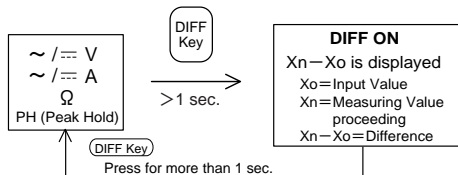

6. MAX / MIN Key

a. Max / Min Measurements

Press MAX/MIN Key once when measuring. For SK-7719, keep pressing this Key for one second or more. MAX MIN symbol appears on LCD and MAX/MIN measurement starts. Each press of this Key works in the following order.

To cancel MAX/MIN Key, press MAX/MIN Key for more than 1 second.

NOTE: AUTO POWER OFF Function does not work when MAX/MIN Key is on.

b. Max / Min Measurements + Display Hold

When measuring MAX/MIN value, press DH Key to hold the value.

NOTE: To cancel DH Key, press DH Key again.

7. RANGE Key (Range Selection : SK-7719 only)

Press RANGE Key to select Manual-ranging for current, voltage or resistance measurements.

The default setting when turning on the power is Autoranging with "AUTO" indication on LCD. In Manual-ranging, this symbol disappears and necessary measurement ranges are selectable in the following ways.

1. Press RANGE Key **before** measurement. Decimal point moves to the next digit by pressing this key. Confirm the decimal point position and select the necessary range.
2. Press RANGE Key **during** Autoranging measurement. The range under measurement is held.

To cancel Manual-ranging and go back to Autoranging, press RANGE Key again for 1 second or more until "AUTO" symbol appears on LCD.

8. LCD

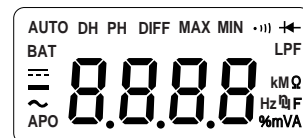

Fig. 2

AUTO	: Autoranging
BAT	: Battery Warning
DC	: Direct Current (DC) on Current and Voltage
-	: Minus symbol automatically shown when polarity is minus.
~	: Alternating Current (AC) on Current and Voltage
APO	: Auto Power Off
DH	: Display Hold
PH	: Peak Hold (SK-7718 only)
DIFF	: Difference Measurements
MAX/MIN	: Max/Min measurements go on. Measuring Value then is shown.
MAX	: Maximum Value
MIN	: Minimum Value
diode	: Continuity test
diode	: Diode Test
mV, V	: Units of Voltage
Ω , k Ω , M Ω	: Unit of Resistance
A	: Unit of Current
Hz	: Frequency
%	: Duty Cycle
⊥	: Capacitance

9. CLAMP HEAD

Open CLAMP HEAD and clamp on a single conductor. When measuring DC current, make sure of the polarity so that the current should flow in the conductor from Front Case (+) to Rear Case (-) according to the \Rightarrow (arrow) mark on the CLAMP HEAD.

NOTE: If two or three conductors are clamped into CLAMP HEAD at a time, the measurement becomes impossible.

10. SAFETY LIMIT Indicator

The line to protect yourself against electrical shock hazard. Do not put your fingers over this line while current measurement.

11. Input Terminals

To measure DC/AC Voltage, insert Test Plugs of Test Leads into COM and V Terminals. To measure Ω , $\bullet||$, \blacktriangleleft , \blacktriangleright , insert Test Plugs into COM and Ω , $\bullet||$, \blacktriangleleft , \blacktriangleright Terminals.

⚠ WARNING : INPUT Terminals are not used to measure Current. For safety, remove Test Leads from INPUT Terminals when measuring Current.

⚠ WARNING : Risk of Electric Shock exists on the Terminal marked with **⚠** when voltage is being measured on COM and V Terminals.

4. SAFETY PRECAUTIONS

Correct knowledge about electric measurements is necessary because electric measurement is sometimes a very dangerous work. To eliminate possibility of injury to the operator and damage to the instrument, the following precautions and measurement procedures must be taken. Misuse, abuse and carelessness cannot be prevented by any written word and is fully the operator's responsibility. Observing the following precautions, take safe measurements.

4-1. WARNINGS

⚠ WARNING 1. Checks of Body and Test Leads

Before every measurement, do not fail to confirm that Body of this instrument and handle insulators of the attached Test Leads have no cracks nor any other damage on them. Make sure that the body and the handle insulators are free of dust, grease and moisture.

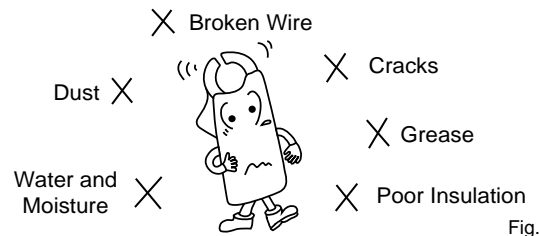

Fig. 3

⚠ WARNING 2. Warning for High Power Line Measurements

High Power Lines (High Energy Circuits) such as Distribution Transformers, Bus Bars, Large Motors, etc. are very dangerous. High Power Line sometimes includes High Surge Voltage that could induce explosive short in the instrument and could result in shock hazard. When measuring voltage of High Power Line, do not touch the Clamp Meter, its Test Leads or any part of the Circuit while it is on.

⚠ WARNING 3. Warning for High Voltage Measurements

Even if with Low Energy Circuits of electric/electronic appliances, heating elements, small motors, line cords and plugs, etc., High Voltage Measurements are very dangerous. Do not touch the Clamp Meter, its Test Leads or any part of the Circuit while it is on. Generally, shock hazard shall be considered to exist at any part involving a potential in excess of 30V rms or 42.4V DC or peak and where a leakage current from that part to ground exceeds 0.5mA.

⚠ WARNING 4. Dangerous Voltage Measurement Procedure

Always observe strictly the following measurement procedure when measuring dangerous voltage.

1. Before measurement, turn off power to the circuit to be measured.
2. Insert Black Test Plug of Test Leads into COM Terminal and Red Test Plug of Test Leads into V Terminal.

— 12 —

— 13 —

3. Attach Black and Red Alligator Clips (optional) to both Test Prods of Test Leads.
4. Set FUNCTION Switch to $\sim V$ position.
5. Confirm that the power of the circuit to be measured is OFF. Then, connect Black Alligator Clip to $-$ (earth) side and Red Alligator Clip to $+$ (positive) side of the circuit to be measured.
6. Place the instrument away from your body, and do not touch it with your hands. Also, take safety distance from the power source or the circuit to prevent any part of your body from touching dangerous voltage.
7. Turn on power to the circuit to be measured and read the voltage on LCD.

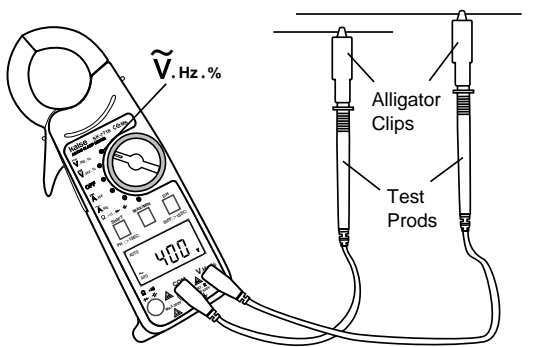

Fig. 4

8. When the measurement is finished, turn off power to the circuit to be measured and discharge all capacitors in the circuit.
9. Disconnect Alligator Clips of Test Prods from the circuit.

— 14 —

In case you want to measure live line, observe following procedure.

1. Place the instrument away from your body.
2. Set FUNCTION Switch to $\sim V$ position.
3. Take safety distance from the power or the circuit to be measured to prevent any part of your body from touching dangerous voltage.
4. Attach Black Alligator Clip to Black Test Prod. Then, connect Black Alligator Clip to $-$ (earth) side of the circuit to be measured.
5. Hold Red Test Prod with one hand and connect it to $+$ (positive) side of the circuit to be measured.
6. Read the voltage on LCD. Refer to the Fig 5.
7. When the measurement is finished, disconnect Red Test Prod from the circuit and then disconnect Black Alligator Clip from the circuit.

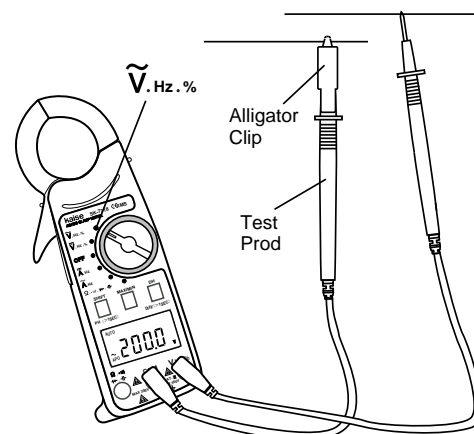

Fig. 5

— 15 —

⚠ WARNING 5. Correct Selection of FUNCTION Switch

When taking measurements, always confirm that FUNCTION Switch is set to correct position. Do not measure voltage on Ω.

•||| . ← . -| position. Refer to the Figure 6.

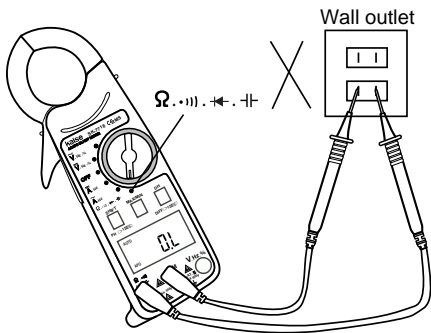

Fig. 6

⚠ WARNING 6. Maximum Input Observance

Do not attempt to measure voltage or current that might exceed the specified maximum input of the function being used.

⚠ WARNING 7. Test Leads Disconnection

Prior to changing FUNCTION Switch to another position when measuring, or removing Rear Case for replacement of batteries, always disconnect Test Leads from the circuit being measured.

⚠ WARNING 8. LIMIT INDICATOR

Do not let the fingers exceed the Limit indicator when measuring current.

LIMIT INDICATOR

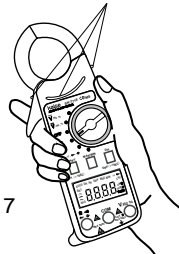

Fig. 7

3. TEST LEADS

Always use Test Leads that complies with IEC specifications (IEC 61010-031 and 600V~) for safety.

Insert Black Test Plug of Test Leads into COM terminal and Red Test Plug of Test Leads into V or Ω / •||| Terminal. Test Prods of Test Leads are connected to the circuit to be measured.

It is good practice to use Black Test Lead for COM Terminal (— polarity) and Red Test Lead for V or Ω / •||| Terminal (+ polarity).

4. FUNCTION Switch

Set FUNCTION Switch to desired position and make certain that all display segments appear for one second.

NOTE: If the display does not appear or BAT symbol appears when FUNCTION Switch is set to desired position, the battery may be consumed.

NOTE: Make certain that DH Key is not pressed ON. If DH Key is operative, measurements can not be performed.

5. AUTO POWER OFF

After about 12 minutes of last operation of FUNCTION Switch or the other Keys, power turns off automatically (goes down in sleep condition and 0.01mW consumption) with LCD displayed off. This function prevents battery consumption when power off is forgotten.

NOTE: To cancel AUTO POWER OFF to make continuous measurements longer than 10 minutes, set Function Switch to desired position with pressing SHIFT Key for less than 1 second.

NOTE: Also AUTO POWER OFF does not work when MAX/ MIN Key is on. Therefore, continuous measurements longer than 10 minutes can be made with MAX/MIN Key pressed on.

4-2. GENERAL WARNINGS AND CAUTIONS

⚠ WARNING 1. Do not let the children use the instrument or those people who are unable to recognize the dangers of electric measurements.

⚠ WARNING 2. Do not make electric measurements in a naked or barefooted state. This will give electric shock hazard to the operator.

⚠ WARNING 3. The points of Test Prods are sharp and dangerous. Do not get hurt with them.

⚠ CAUTION 1. Do not polish the meter case, or attempt to clean it with any cleaning fluid, gasoline, benzine, etc. If necessary, use silicon oil or antistatic fluid.

⚠ CAUTION 2. Avoid severe mechanical shock or vibration, extreme temperature or very strong magnetic field.

⚠ CAUTION 3. Remove the batteries when not in use for an extended time since the exhausted batteries might leak electrolyte and corrode the internal components.

5. MEASUREMENT PROCEDURES

5-1. PREPARATION FOR USE

1. INSTRUCTION MANUAL ⚠

Prior to use, read INSTRUCTION MANUAL carefully and acquaint yourself with the specifications and functions of the instrument. Especially, read and observe strictly the 「4. SAFETY PRECAUTIONS」.

2. BATTERY

One 9V 6F22 battery is furnished with this instrument. When the battery is consumed and a BAT symbol is shown on LCD, open Rear Case and replace the battery. Refer to 「6-2. BATTERY REPLACEMENT」 on page 28 to 29.

6. POWER-ON INITIALIZE (effective for DC current measurement)

The instrument performs POWER-ON INITIALIZE automatically when turning on the power.

This function is effective when turning on the power without any inputs. If any inputs are applied to the instruments, it does not work correctly. LCD will display 0±1 digit when INITIALIZE was done correctly. If LCD does not display it, turn the power on again or press DIFF Key.

NOTE: INITIALIZE sometimes does not work correctly due to some CPU error even if no inputs are applied. If LCD displays 3 digits or more, use DIFF Key.

NOTE: For current measurements near the high current conductor, INITIALIZE does not work correctly. In this case, take the instruments away from the conductor, and turn the power on again.

7. OVERLOAD INDICATION

For Current and Voltage measurement, "OL" symbol **IS NOT** displayed on LCD even if the input value exceeds their maximum input value, 1000A AC/DC or 600V AC/DC.

⚠ WARNING

Do not attempt to make any measurements that might exceed the maximum value of the function being used to avoid electrical shock hazard and/or damage to the instrument.

8. SYMBOL MARK

The following symbols shown on the instrument and in the instruction manual are listed in IEC 61010-1 and ISO 3864.



⚠ : Warning or Caution (refer to instruction manual.)

⚡ : Warning, risk of electric shock

— : Direct Current (DC)

~ : Alternating Current (AC)

≈ : DC and AC

-  : Earth (Ground)
-  : Double Insulation

5-2. CURRENT (\bar{A} . \tilde{A} . Hz) MEASUREMENTS

WARNING

Maximum Input Current of AC/DC Current Function is 1000A(600V line). Do not attempt to measure any current that might exceed 1000A AC/DC. Prior to measurements, read carefully 「4. SAFETY PRECAUTIONS」 of this instruction manual to avoid electrical shock hazard and/or damage to the instrument.

1. Set FUNCTION Switch to desired \bar{A} or \tilde{A} position.
On \bar{A} position, LCD shows random digits. But this does not affect the specified accuracy.

WARNING

Test Leads are not required for Current Measurements. For safety measurements, remove Test Leads from INPUT Terminals. Do not touch any part of the Power Line or the Circuit while it is on.

2. Open CLAMP HEAD and clamp on a single conductor.
NOTE : If two or three conductors are clamped on at a time, the measurement cannot be made.
NOTE : In case of measuring DC current, clamp on the conductor with Front Case faced to + polarity.
3. Read the current on LCD.
4. Hz : Press SHIFT Key while \bar{A} or \tilde{A} measurements.
5. Display Hold, Difference, Max/Min, Peak Hold (SK-7718 only) and Range Selection (SK-7719 only) are available. Refer to DH Key, DIFF Key, MAX/MIN Key, PH Key and RANGE Key on page 8 to 10. In PH Mode, 2~3A remain.
6. When measurements are finished, remove CLAMP HEAD from the circuit and set FUNCTION Switch to OFF position.

— 20 —

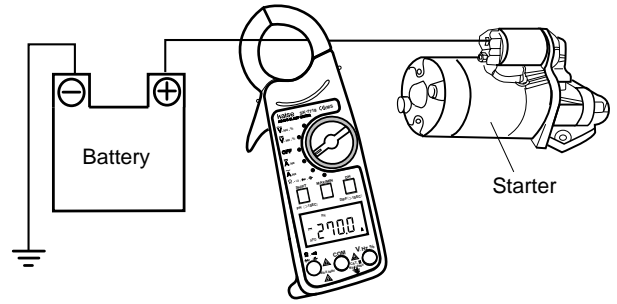

Fig. 8

5-3. VOLTAGE (\bar{V} . \tilde{V} . Hz . %) MEASUREMENTS

WARNING

Maximum Input Voltage of V function is 600V. Do not attempt to measure voltage that might exceed 600V. Prior to measurements, read carefully 「4. SAFETY PRECAUTIONS」 of this instruction manual to avoid electrical shock hazard and/or damage to the instrument.

1. Insert Black Test Plug into COM Terminal and Red Test Plug into V . Hz . % Terminal.
2. Set FUNCTION Switch to desired \bar{V} or \tilde{V} position.
Random digits are shown LCD. But, this does not affect the specified accuracy.
3. Connect Black Test Prod to the negative (earth) side of the circuit being measured and Red Test Prod to the positive (high potential) side of the circuit.

— 21 —

NOTE : When taking voltage measurements, always connect the instrument **IN PARALLEL** with the circuit being measured.

WARNING

When measuring dangerous voltage more than 220V, turn off power to the circuit to be measured and connect Test Prods to the circuit using Alligator Clips (optional). Do not touch the Clamp Meter, its Test Leads or any part of the Circuit while it is on. Refer to 「WARNING 4. Dangerous Voltage Measurement Procedure」 on page 13 to 15.

4. Read the voltage on LCD.
5. Hz and % : When measuring \bar{V} or \tilde{V} , press SHIFT Key to measure Hz and %.
6. Display Hold, Difference, Max/Min, Peak Hold (SK-7718 only) and Range Selection (SK-7719 only) are available. Refer to DH Key, DIFF Key, MAX/MIN Key, PH Key and RANGE Key on page 8 to 10.
7. When measurements are finished, remove Test Prods from the circuit and set FUNCTION Switch to OFF position.

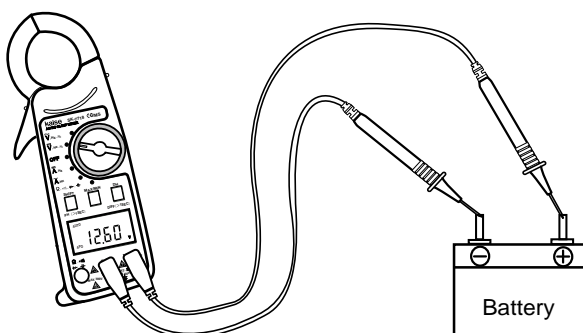

Fig. 9

— 22 —

5-4. RESISTANCE (Ω) MEASUREMENTS

WARNING

Do not measure Voltage on Ω . $\bar{\Omega}$. $\tilde{\Omega}$ position. This will cause shock hazard to the operator and damage to the instrument. In case in-circuit resistance is measured, turn off power to the circuit being measured and discharge all capacitors in the circuit. Prior to measurements, read carefully 「4. SAFETY PRECAUTIONS」 of this instruction manual.

1. Insert Black Test Plug into COM Terminal and Red Test Plug into Ω . $\bar{\Omega}$. $\tilde{\Omega}$ Terminal.
2. Set FUNCTION Switch to Ω . $\bar{\Omega}$. $\tilde{\Omega}$ position.
3. If the resistor to be measured is connected in a circuit, turn off power to the circuit and discharge all capacitors in the circuit.
4. Open one side of the resistor to be measured and connect Test Prods to both sides of the resistor (or circuit).
5. Read the resistance on LCD.
6. Display Hold, Difference, MAX/MIN and Range Selection(SK-7719 only) are available. Refer to DH Key, DIFF Key, MAX/MIN Key and RANGE Key on page 8 to 10.
7. When measurements are finished, remove Test Prods from the resistor (circuit) and set FUNCTION Switch to OFF position. Then restore the circuit as it was.

— 23 —

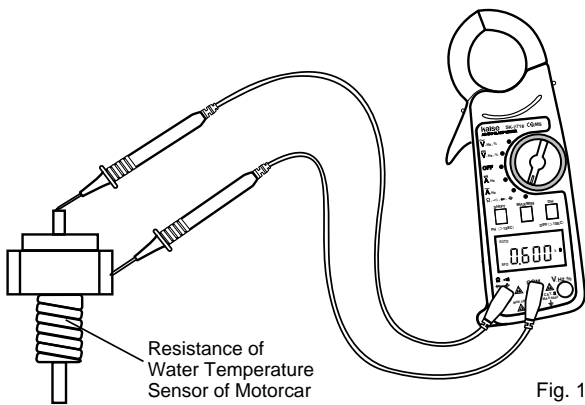

Fig. 10

5-5. CONTINUITY () TESTS

⚠ WARNING

Do not measure Voltage on Ω position. This will cause electrical shock hazard to the operator and/or damage to the instrument. In case continuity test is made, turn off power to the circuit being measured and discharge all capacitors in the circuit.

1. Insert Black Test Plug into COM Terminal and Red Test Plug into Ω Terminal.
2. Set FUNCTION Switch to Ω position.
3. Press SHIFT Key once to display . . . symbol on LCD.
4. Turn off power to the circuit and discharge all capacitors in the circuit.
5. Connect Test Prods of Test Leads to the circuit to be tested. Buzzer sounds when the resistance value is less than approx. 50 Ω .

6. When measurements are finished, remove Test Prods from the circuit and set FUNCTION Switch to OFF position. Then restore the circuit as it was.

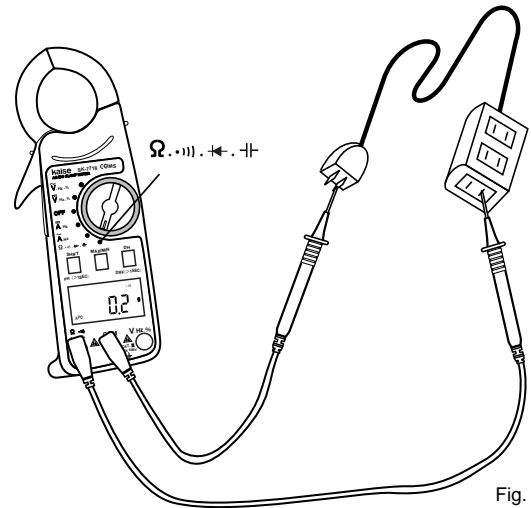

Fig. 11

5-6. DIODE () TESTS

⚠ WARNING

Do not measure Voltage on Ω position. If the diode is connected in a circuit, turn off power to the circuit and discharge all capacitors in the circuit. Disconnect one side of the diode and test it.

1. Insert Black Test Plug into COM Terminal and Red Test Plug into Ω Terminal.
2. Set FUNCTION Switch to Ω position.
3. Press SHIFT Key twice to display \rightarrow symbol on LCD.
4. If the diode is connected in a circuit, turn off power to the circuit and discharge all capacitors in the circuit and disconnect one side of diode from the circuit.
5. Connect Black Test Prod to Anode and Red Test Prod to Cathode of the diode being measured. This is Reverse Connection. Confirm that the LCD displays OL symbol. Refer to the figure 13.
6. Reverse Test Prod connection to the diode being tested. This is Forward Connection. In case of Silicon diodes, LCD displays 0.1V to 0.4V, and the diodes are judged good.
7. When measurements are finished, remove Test Prods from the diode and set FUNCTION Switch to OFF position.

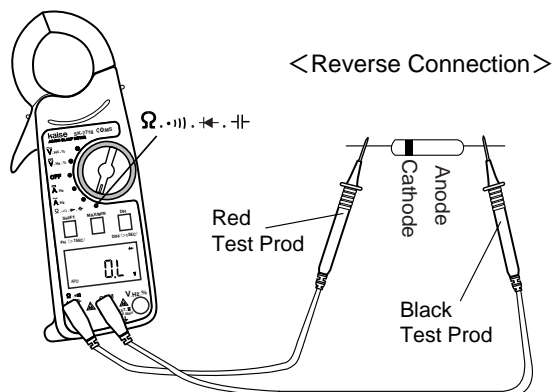

Fig. 12

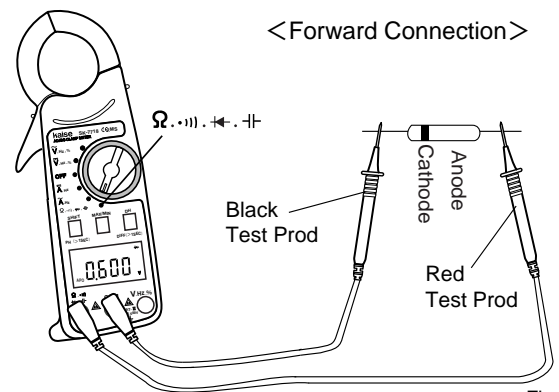

Fig. 13

5-7. Capacitance () MEASUREMENTS

⚠ WARNING

Do not measure Voltage on Ω position. This will cause electrical shock hazard to the operator and damage to the instrument. Before taking capacitance measurements, remove power to the circuit being measured and discharge all the capacitors in the circuit.

1. Insert Black Test Plug into COM Terminal and Red Test Plug into Ω Terminal.
2. Set Function Switch to Ω position.
3. Press SHIFT Key 3 times to display nF unit on LCD.
4. Press DIFF Key for more than 1 second to display 0±1 digit on LCD only in case it shows more digits.
5. Remove power to the circuit being tested and discharge all capacitors in the circuit.
6. Open one side of the capacitor to be measured and connect Test Prods of Probe Tester to the capacitor.
7. Read the capacitance on LCD.

8. After measurements, set FUNCTION Switch to OFF position.
NOTE : Measurement time takes longer to measure higher capacitance. (Example : approx. 4 sec. at 10 μ F, approx. 14 sec at 90 μ F.)

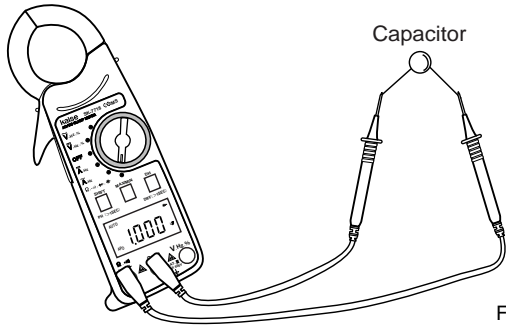

Fig. 14

6. MAINTENANCE

6-1. WARRANTY STATEMENT

The warranty statement for the Clamp Meter is printed on the last page of the manual. Read it carefully before requesting a warranty repair.

6-2. BATTERY REPLACEMENT

WARNING

To prevent electrical shock hazard, remove both Test Leads from external circuit connections and from the Input Terminals before removing Rear Case to replace the batteries.

1. If the battery is consumed and BAT symbol is shown on LCD, replace the battery.
2. Remove both Test Leads from the circuit and from the Terminals.
3. Set FUNCTION Switch to OFF position.

— 28 —

4. Remove Rear Case unscrewing the 4 screws.
5. Take out the worn-out battery from Battery Case.
6. Place one fresh 9V 6F22 battery in Battery Case.
NOTE : If the battery is installed in the wrong polarity, the display will not be shown when FUNCTION Switch is turned on.
 Do not leave the instrument in this condition as it results in battery consumption.
7. Replace Rear Case.

NOTE : If the instrument is taken out of service for an extended time, remove the battery from Battery Case and store separately.

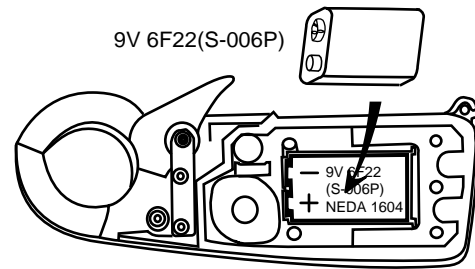
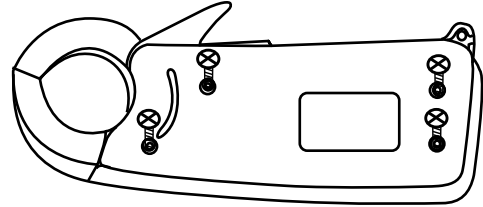

Fig. 15

— 29 —

6-3. PERIODICAL CHECK AND CALIBRATION

Periodical check and calibration are necessary to make safety measurements as well as to maintain the specifications described on page 3 to 7.

It is recommended that the instrument may be checked and calibrated once each year and/or after it is repaired. Periodical Check and Calibration services are available at KAISE AUTHORIZED SERVICE AGENCY through your local dealer at a cost basis charge.

Pack the instrument securely in its original carton together with descriptions of your name, address, telephone number and the service required, and ship prepaid to your local dealer.

6-4. REPAIR

Repair service, warranty or non-warranty, is available at KAISE AUTHORIZED SERVICE AGENCY through your local dealer. Warranty repair is executed free of charge, but, non-warranty repair is charged on the cost basis.

Pack the instrument securely in its original carton together with descriptions of your name, address, telephone number, problem encountered and the service required, and ship prepaid to your local dealer.

When the instrument does not operate properly, the following steps should be taken before returning the instrument for repair, warranty or non-warranty.

SYMPTOM	POSSIBLE CAUSE	NECESSARY STEPS
No Display.	Low Battery.	Replace the battery. (Refer to P28.)
	Battery is installed in the wrong polarity.	Install battery in the correct polarity.
Readings are not stable on all functions.	The contact of Plugs of Test Leads is bad.	Confirm the contact of Plugs.
	Influence of noise.	Use a suitable shield or keep away from noise.
FUNCTION Switch is set to desired position and LCD displays some value under no input being applied.		If LCD displays less than 3 digits, continue the measurement. If LCD displays more than 4 digits and INITIALIZE is not performed exactly, press DIFF Key to display 0±1 digit on LCD and perform measurements. In this case, accurate measurements are ensured.

WARRANTY

The Clamp Meters, SK-7718/7719 are warranted in its entirety against any defects of material or workmanship under normal use and service within a period of one year after the date of purchase of the instrument by the original purchaser. This warranty is extended by **KAISE AUTHORIZED DEALER** only to original purchaser or original user of the instrument on condition that the Warranty Registration Card is completed and returned to the authorized dealer within two weeks after the purchase of the instrument new from the dealer. The obligation under this warranty to be executed by **KAISE AUTHORIZED DEALER** is limited to repairing or replacing the Clamp Meters SK-7718/7719 returned intact to it, with transportation charge prepaid, and which to its satisfaction is judged by it to have been thus defective. **KAISE AUTHORIZED DEALER** and **KAISE CORPORATION**, the manufacturer shall not otherwise be liable for any damages or loss, consequential or otherwise. The foregoing warranty is exclusive and in lieu of all other warranties including any warranty of merchantability, whether expressed or implied.

This warranty shall not apply to any instrument or other article of equipment which shall have been repaired or altered outside **KAISE AUTHORIZED SERVICE AGENCY**, nor which has been subject to misuse, negligence or accident, incorrect wiring by users, or installation or use not in accord with instructions furnished by the manufacturer.

KAISE AUTHORIZED DEALER

MEMO

KAISE CORPORATION

422 Hayashinogo, Ueda City, Nagano Pref.,
386-0156, Japan

TELEPHONE : +81-268-35-1600(REP.)

FAX : +81-268-35-1603

E-mail : sales@kaise.com

<http://www.kaise.com>

Product specifications and appearance are subject to change without notice due to continual improvements.

kaise



INSTRUCTION MANUAL

**AC / DC
DIGITAL CLAMP METER**

**MODEL SK-7718
SK-7719**

KAISE CORPORATION